

TEKNİK VERİLER | TECHNICAL DATA

2+4 DELİKLİ SAE B KAMALI ÇİFT YÖNLÜ DİŞLİ MOTOR
2+4 HOLES SAE B KEYED BI-DIRECTIONAL GEAR MOTOR

Giriş Basıncı Inlet Pressure	0.3÷ 2 bar		
Çalışma Viskozite Seviyesi Operating Viscosity Range	-12:100 cSt		
Sıvı Sıcaklığı Fluid Temperature	-40 °C+145 °C		
Çalışma Basıncı Working Pressure	Kirlilik Contamination		Filtre Filter
	NAS 1638	ISO 4406	$\beta_x=75$
≥200 bar	11	20/17	25 μ m
≤200 bar	12	21/18	40 μ m

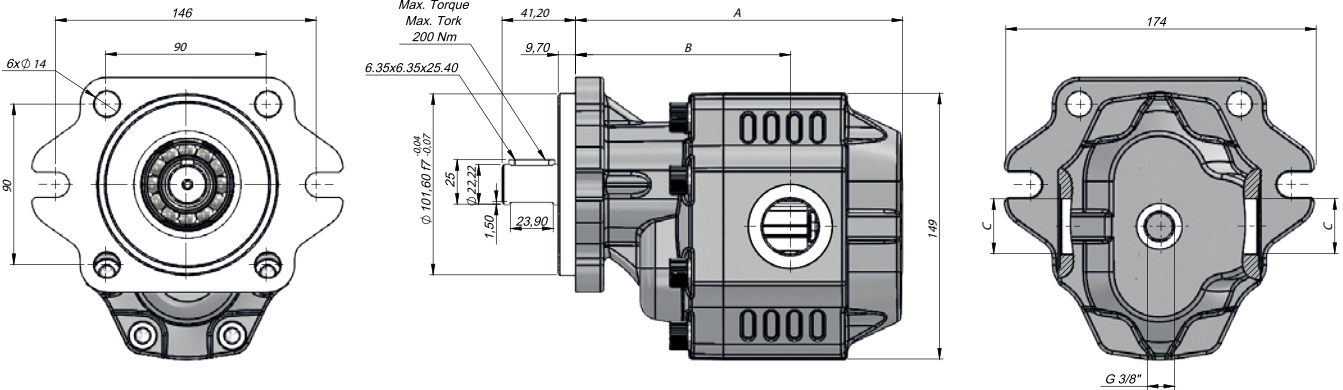

Kod Code	İletim Hacmi Displacement	Maks.Sürekli Basınç Max.Continuous Pressure	Min. Hız Min.Speed	Maks.Sürekli Hız Max.Continuous Speed	A	B	Giriş Inlet	Çıkış Outlet
BD	(cm ³ /rev)	(100%)(BAR)	(RPM)	(RPM)	(mm)	(mm)	C	C
GM30017BK131	17	300	300	2500	150	103	G1/2"	G1/2"
GM30027BK131	27	290			156	108		
GM30034BK131	34	285		2200	161	109	G3/4"	G3/4"
GM30043BK131	43	280			167	114		
GM30051BK131	51	230			172	114		
GM30061BK131	61	225		1800	180	120,5	G1"	G1"
GM30073BK131	73	215			192,5	122,5		
GM30082BK131	82	200		1600	191	124,5	G1"	G1"
GM30100BK131	100	190			204	138,5		
GM30125BK131	125	170			220	142,5		